

Bestellcode / Order code / Article	VULZ H 10 VULZ H 11 VULZ H 40 VULZ H 20 VULZ H 21 VULZ H 30
------------------------------------	--

Prüfungen | Meets requirement limit values for | Législation

EN 13 240	●
15a B-VG	●
DIN plus	●
BImSch V 2	●

Leistungseigenschaften | Features during operation | Caractéristiques de fonctionnement

Ekodesign (Raumheizungs-Jahresnutzungsgrad) Ekodesign (Seasonal energy efficiency of heating) Eco design (Efficacité énergétique de chauffage de saison)	%	71,1
Energieeffizienzindex (EEI) Energy efficiency index (EEI) Indice d'efficacité énergétique (IEE)		107,2
Energieeffizienzklasse Energy Label Label énergétique		A+
Verwendeter Brennstoff Fuel Type de combustible		Stück Holz/Piece wood/Bûches
Ausmaß des Brennstoff Length of fuel Longueur de bûches	mm	250
Durchschnittlicher Brennstoffverbrauch Average wood consumption Consommation moyenne de combustible (bûches)	kg/h	1,24
Maximal Brennstoffverbrauch Allowed wood batch Lot de combustible autorisé	kg/h	2,2
Zeitabstand der Brennstoffbeschickung für die Nennleistung Fuel supply interval for the rated output Intervalles de charge du combustible		1 Stunde/1 hour/1 heure
Verbrennungsluftbedarf Combustion air requirement Volume de chauffe	m ³ /h	15,7

Nennwertes | General data | Valeurs nominales

Nennwärmeleistung Nominal heat output Puissance nominale	kW	5,7
Reg.Gesamtleistung Reg.output Puissance ajustable	kW	2,9 - 7,4
Wirkungsgrad Efficiency Rendement	%	80,14
Massendurchfluss von trockenen Abgasen Dry flue gases mass flow Débit massique des fumées	g/s	4,2
Durchschnittliche Abgastemperatur Mean flue gas temperature Température moyenne des résidus de combustion	°C	241
Durchschnittliche Rauchgastemperatur nach dem Hals Mean flue gas temperature after throat Température moyenne des résidus de combustion derrière la sortie	°C	284
Förderdruck Flue draught Tirage de conduit de fumée	Pa	12
Staub - O ₂ =13% Dust - O ₂ =13% Poussière - O ₂ =13%	mg/m ³	38
CO - O ₂ =13%	mg/m ³	1005
CO ₂	%	8,63
OGC - O ₂ =13%	mg/m ³	56
NO _x - O ₂ =13%	mg/m ³	85

Maße & Gewicht | Dimensions and weights | Dimensions et poids

Maße (Höhe x Breite x Tiefe) Dimensions (Height x Width x Depth) Dimensions (hauteur x largeur x profondeur)	mm	1679 x 496 x 496 (VULZ H 10)
Anschlusshöhe (seitlichen) hinten Connection height for rear (side) installation Hauteur de l'axe de la sortie arrière (latéral)	mm	1069
Rauchrohrdurchmesser Flue gas connector diameter Diamètre du conduit de fumée	mm	150
Zentralluftzufuhr (ZLZ) External air intake (EAI) Diamètre de l'arrivée d'air central (AAC)	mm	125
Gewicht Weight Poids	kg	215 (VULZ H 10)
Maße Feuerraum (Höhe x Breite x Tiefe) Dimensions of the combustion chamber (Height x Width x Depth) Dimensions de la chambre de combustion (hauteur x largeur x profondeur)	mm	500 x 284 x 291
Sicherheitsabstand von brennbaren Werkstoffen (Hinterwand x Frontwand x Seitenwände x Seite mit Glas x Von der Decke) Safe distance from flammable materials (Back x Front x Side x Side with glass x From the ceiling) Distance de sécurité par rapport aux matériaux combustibles (arrière x frontal x latéral x latéral avec vitre x plafond)	mm	200/800/200/800/800

Mitgeliefertes Zubehör | Supplied accessories | Accessoires fournis avec le produit

Schutzhandschuh Protective glove Gant de protection	●
Aschenbecher Ashtray Cendrier	●

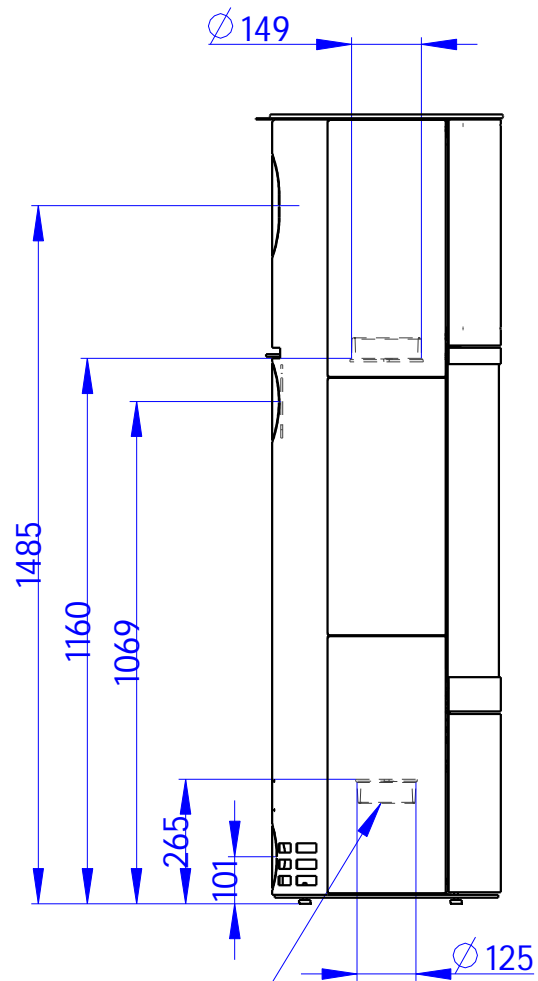
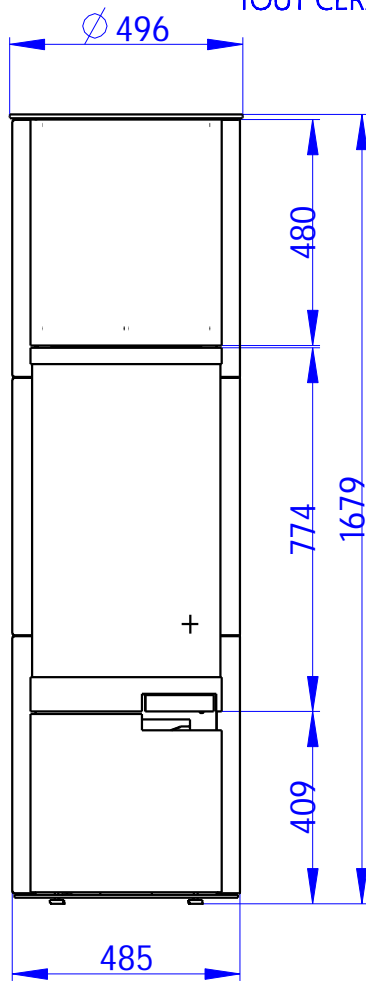

Zentralluftzufuhr
Central air inlet
Arrivée d'air central

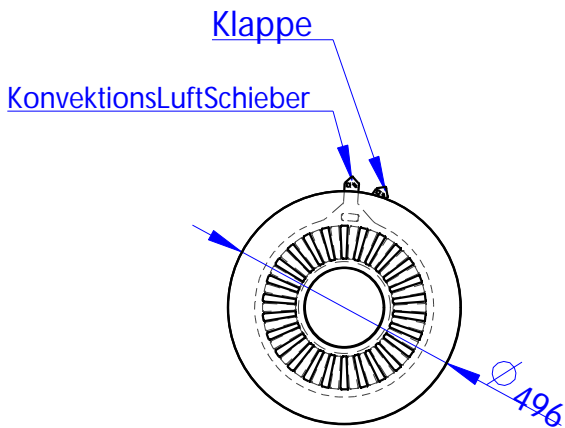

Primärluft
Sekundärluft
Primary air
Secondary air
Air primaire
Air secondaire

Rostzugstange
Grate lever
Levier à grille

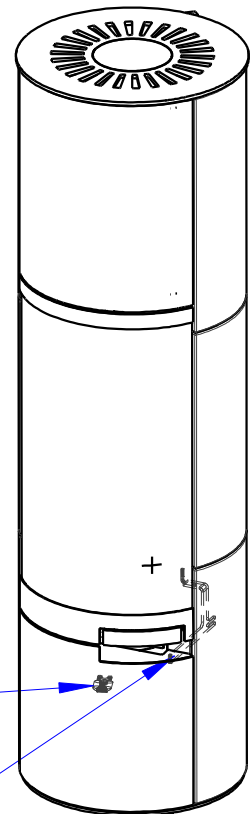

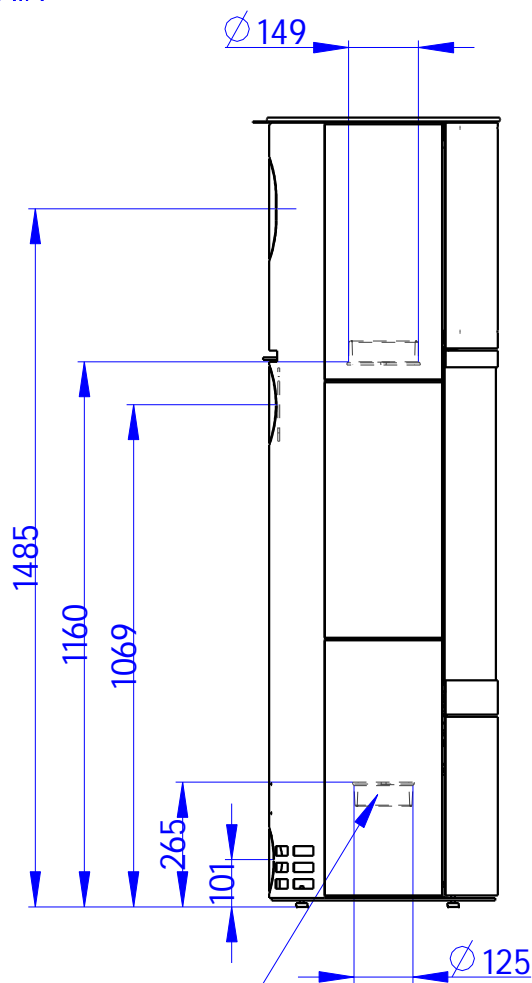
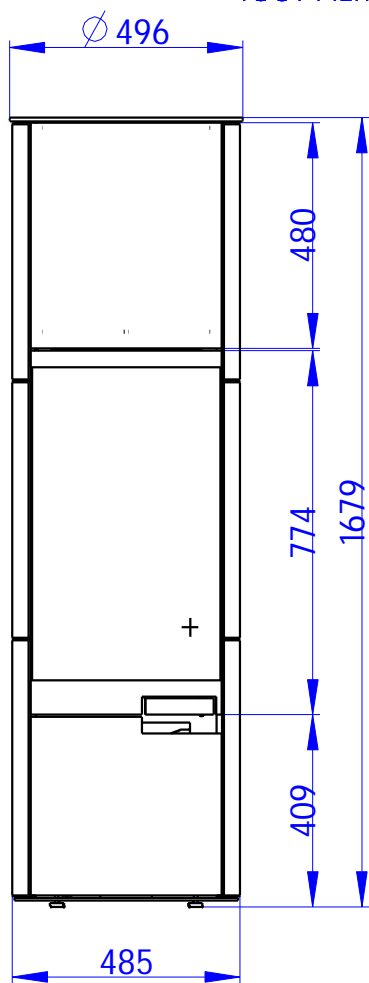

Zentralluftzufuhr
Central air inlet
Arrivée d'air central

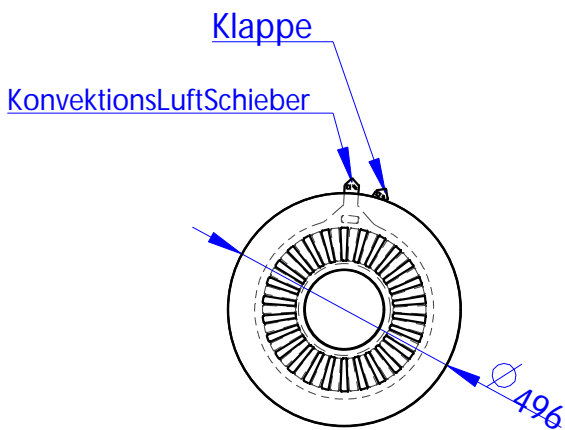

Primärluft
Sekundärluft
Primary air
Secondary air
Air primaire
Air secondaire

Rostzugstange
Grate lever
Levier à grille

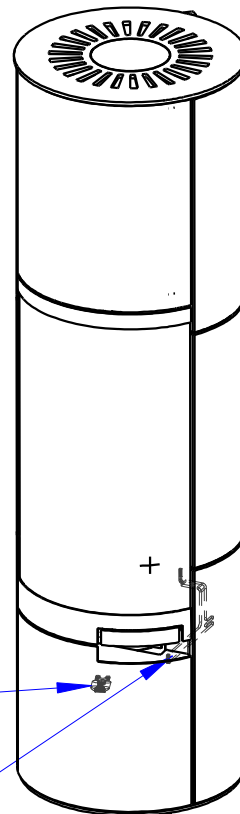

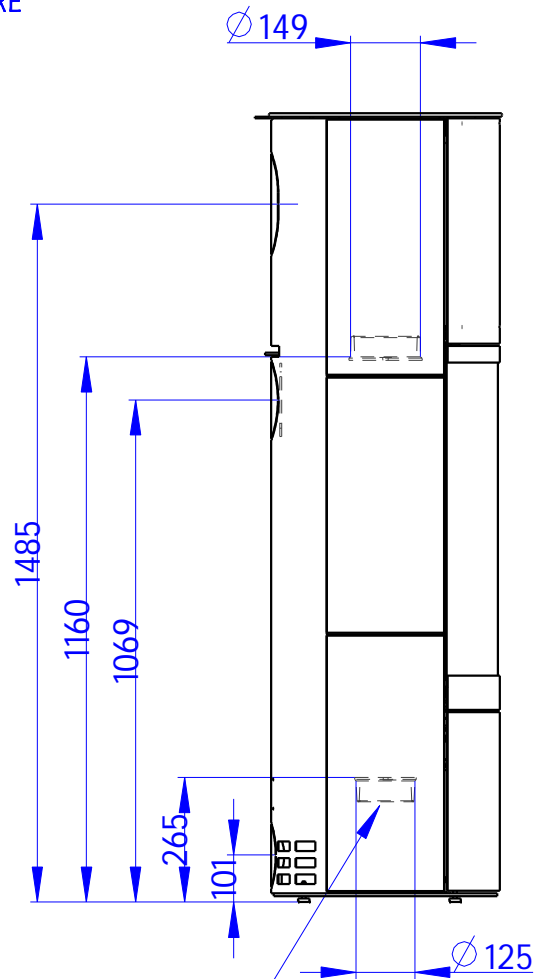
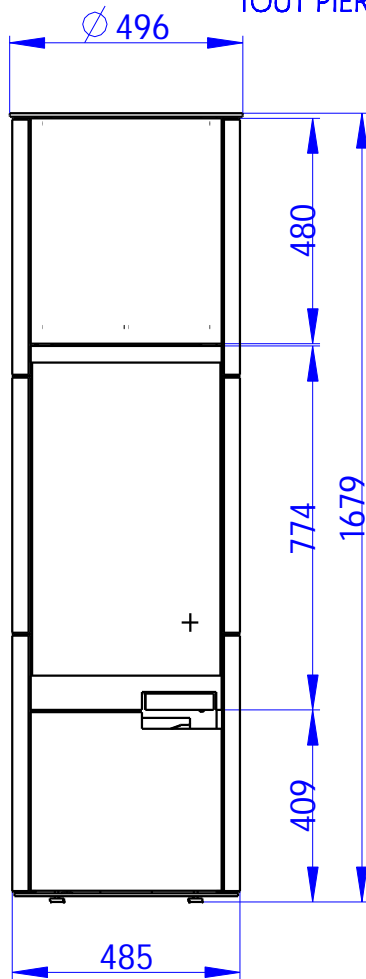

Zentralluftzufuhr
Central air inlet
Arrivée d'air central

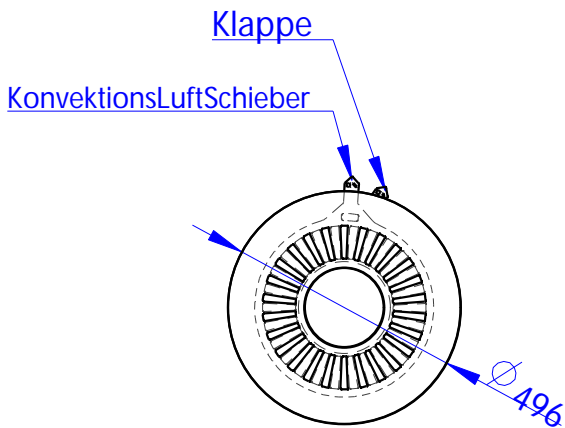

Primärluft
Sekundärluft
Primary air
Secondary air
Air primaire
Air secondaire

Rostzugstange
Grate lever
Levier à grille

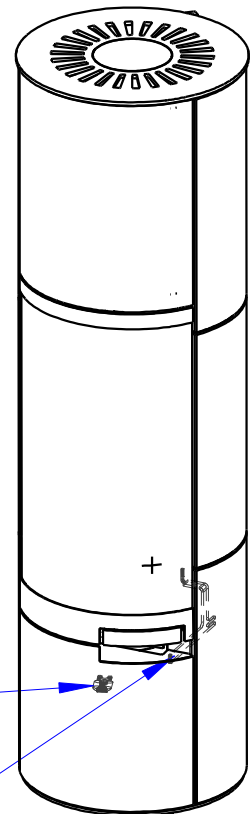

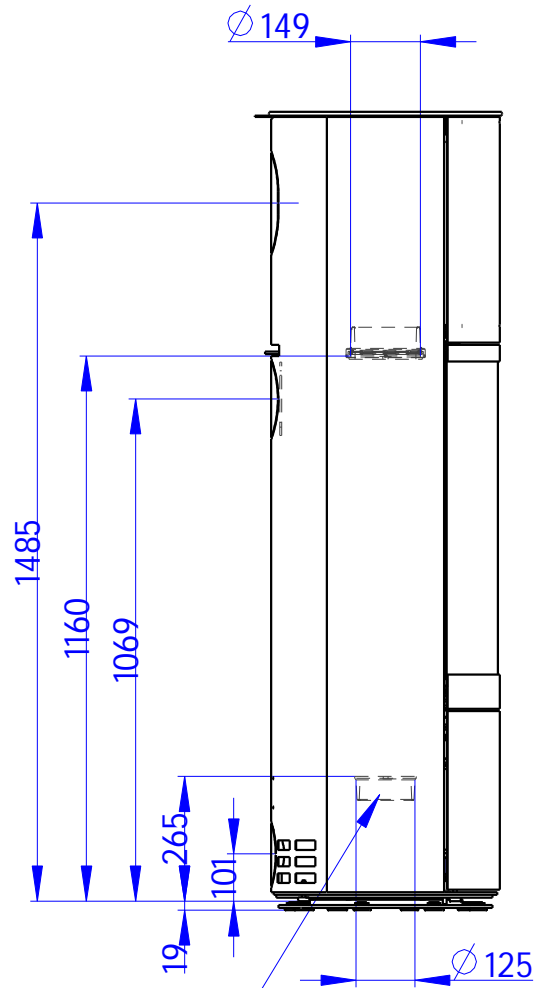
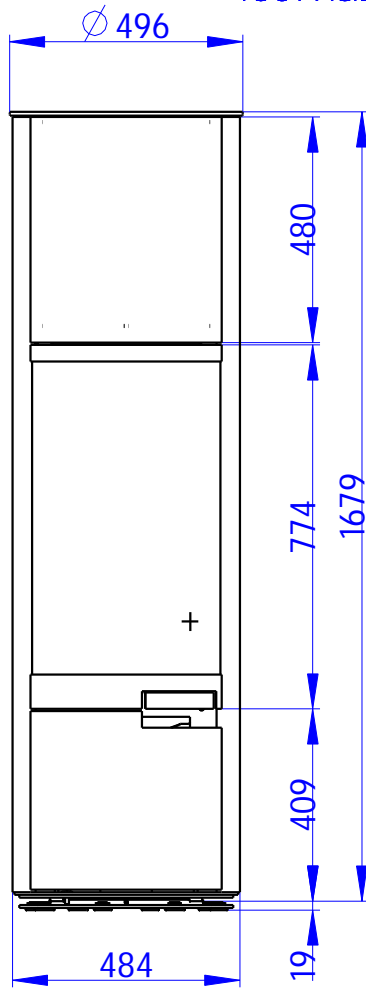

Zentralluftzufuhr
Central air inlet
Arrivée d'air central

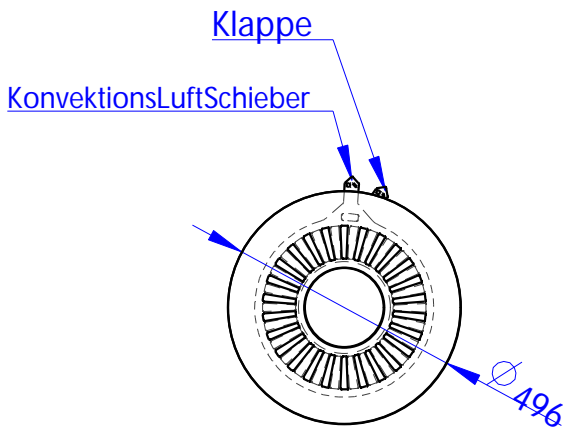

Primärluft
Sekundärluft
Primary air
Secondary air
Air primaire
Air secondaire

Rostzugstange
Grate lever
Levier à grille

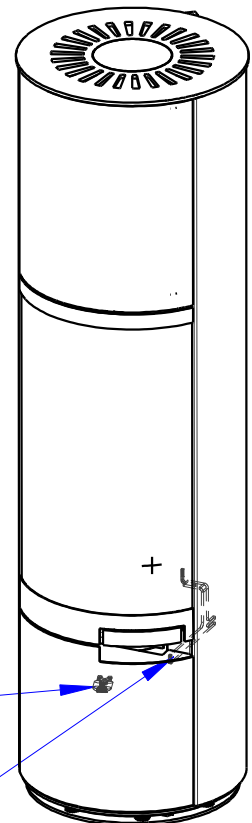

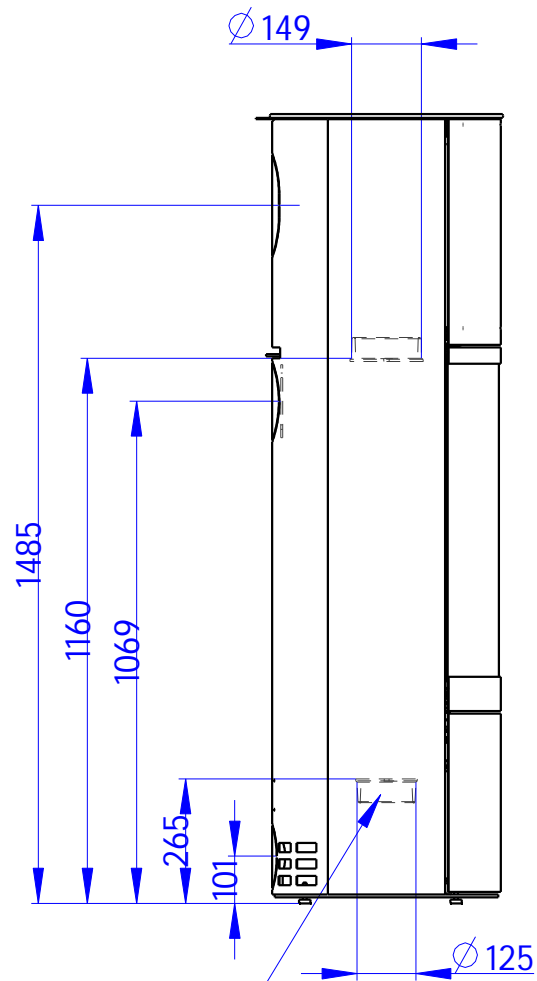
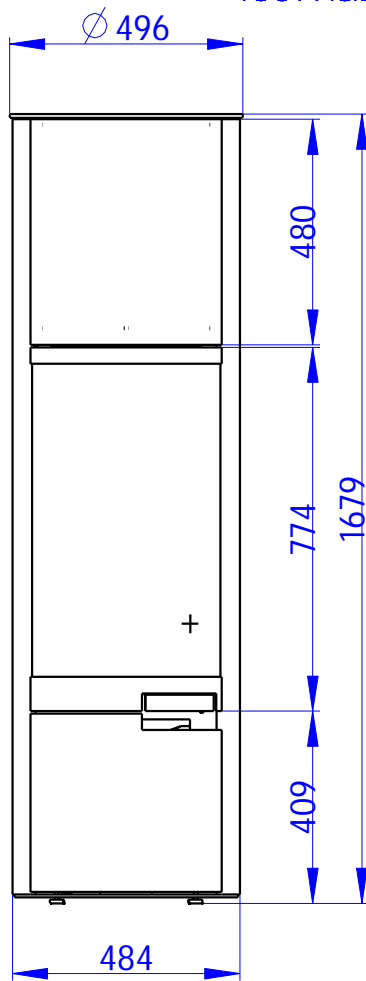

Zentralluftzufuhr
Central air inlet
Arrivée d'air central

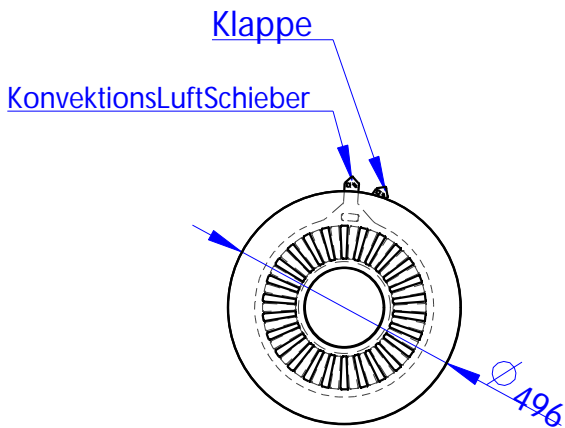

Primärluft
Sekundärluft
Primary air
Secondary air
Air primaire
Air secondaire

Rostzugstange
Grate lever
Levier à grille

